

Adaptive Beamforming with a Microphone Array

Project Outline:

The objective of this project is to implement an adaptive beam-forming algorithm for a microphone array, on Xtensa processor. The model set-up is shown in the figure below

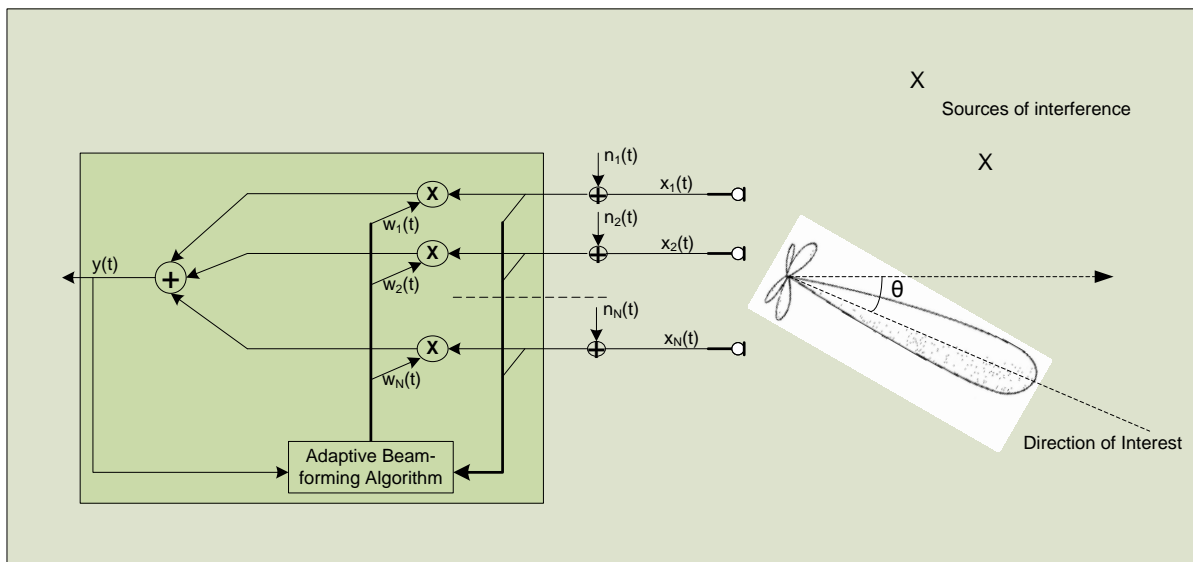

The algorithm should adaptively form the beam towards the source, thus maximizing the SNR for the direction of interest and suppress interference. Also, as the direction of interest (DOI) changes, the beam should move to the new DOI automatically.

$x_i(t)$: Digital audio signal from Microphone “i”. This includes the signal from the “Direction of Interest” as well as interference/ambient noise picked up by the microphone

$n_i(t)$: Additive noise at Microphone “i”. Different n_i ’s are uncorrelated with each other

$w_i(t)$: Weight to be applied to the input from Microphone “i”. The weights are determined by the Adaptive Beamforming Algorithm

$y(t)$: Final output, after the beamforming

N : Number of microphones.

Parameters

- $N = 8$
- Spacing between adjacent microphones: Flexible -- you can choose (it need not be uniform)
- Maximum length of the array (distance between microphones at two extreme ends) = 35 cm

- Sampling Rate = 16 kHz
- Sample size = 16b
- $n_i(t)$ at any microphone is -3dB of the signal ($x_i(t)$)
 - Spectrum of n_i is proportional to $1/f$
- $x_i(t) = s(t) + i_1(t) + i_2(t) + b(t)$ where
 - $s(t)$: Signal of interest
 - $b(t)$: Diffused background noise (omni-directional)
 - $i_1(t), i_2(t)$: Discrete sources of interference
- $b(t) = -10\text{dB}$ compared to $s(t)$
- $i_1(t), i_2(t)$: Each can be up to -3dB of $s(t)$

Success Criteria:

- Working model that demonstrates, given the parameters above,
 - Ability to identify DOI, with a resolution of 15 degrees (with randomly placed discrete sources of interference)
 - Convergence of weights within 100 ms (both at start-up as well as when the DOI changes)
- Evaluation would be based on relative performance. Parameters that shall be used to evaluate the projects:
 - Code size
 - Minimum clock rate required to implement the algorithm
 - Convergence time
 - SNR improvements due to Beamforming

What is expected in the project report

- A clear description of the algorithm architecture and design. This must include clear references to the existing literature/algorithms that are being leveraged for this project
- Novelty – innovation may be in the algorithm, optimizations specific to Xtensa processor and/or in the test setup
- Verification strategy – give a clear description of the test setup, characteristics of signal/noise/interference that are used and different scenarios that are tried out to demonstrate the correct operation and robustness of the algorithm
- Results – it is expected that results would not be obtained in one go and a typical development process would involve iterations of optimizations and analysis of the profiling numbers (code size, performance). Please include a description of the iterations and the improvements realized during the course of project development

Prize:

- Winning team - **Rs. 35,000** (all team members, including guide)
- Runner up team - **Rs. 15,000** (all team members, including guide)

Timeline

Call for papers open	25 Nov 2014
Call for papers closed	19 Jan 2014
Papers due from submitters - second round	20 March 2015
Submitters informed - second round	30 April 2015
Top teams final live presentation	15 May 2015
Winners announced	22 May 2015

How to Submit

- Go to your category page, click on the “Submit Now” link at the end of the page to download the abstract submission form
- Download and save the form
- **All mandatory fields of the abstract submission form must be filled in full; incomplete forms will not be accepted**
- Please email your abstract submission form in Word format ONLY (no PDFs) to designcontest_india@cadence.com

Contest Rules

- The university/institute must be enrolled as part of the Cadence® University Program at the time of submitting the abstract for the Contest
- Maximum of four students per submission

If your abstract is selected for the second round of this contest, you will be given a temporary tool license to work on this project. You must sign an agreement to use this temporary license.

For more information about the license, please visit www.tensilica.com/company/university-program/license-application.

For more information, please contact designcontest_india@cadence.com.